



Leica DMI 5000 M

Simply Microscopy!

The Standard in Inverted
DigitalMicroscopy

Leica
MICROSYSTEMS

Intelligence
Brilliance
Integration
Flexibility

The Standard in Inverted Digital Microscopy

Our mission is to visualize your materials research in the very best light. Our optical & design engineers focused their entire expertise on this goal. The result is the Leica DMI 5000 M, the successor of the famous Leica MeF4. However, it is not only the best possible image quality that drives us. The intelligent operation of the Leica DMI 5000 M will let you experience the pleasure of professional microscopy without the work. Using a microscope has never been this simple; you can always depend on receiving a system custom-tailored to your application requirements with the DMI 5000 M. It is the optimum solution for your tasks in R&D, quality assurance and testing.

Intelligent imaging – at the touch of a button

You will be impressed by the intelligence of the Leica DMI 5000 M. This microscope makes it extraordinarily simple for you to generate outstanding images regardless of contrast, illumination or intensity settings. At the touch of a button, the DMI 5000 M insures sharp, brilliant images every time.

Experience and innovation – the art of creating brilliant images

The new reflected-light axis is a Leica innovation which offers everything you expect from a light microscope in brilliance, depth of field and resolution. It wouldn't bear the Leica name if you could not expect something really innovative like the integrated "Inclusion Counter" steel purity module.

Secure foundation for future expansion

The Leica DMI 5000 M gives you the choice – a manual stand with a fixed stage and manual focus right through to a fully motorized stand. Upgrades are possible at any time, such as adding the motorized DIC system.

A team is more powerful than the sum of its players

Leica products are team players that are designed to work together to tackle your applications more efficiently than ever. The Leica line ranges from microscopes and digital cameras to software solutions for a wide variety of applications. Assemble your own system from our range – all components operate perfectly together.

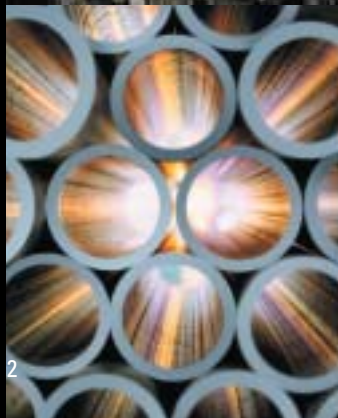



Leica Design by Christophe Apothélos



Gray cast iron, lamellar pearlite graphite, POL, 1:1500



“Maximum transmission, homogeneity and optimum contrast were the targets for the development of the Leica DMI5000 M. The result is an instrument with a completely new optical system that meets the highest demands for true object and color reproduction of your material specimens.”

Stefan Motyka, Marketing Manager Industry, Leica Microsystems



Gray cast iron, lamellar pearlite graphite, BF, 1:1500

Photo: Ursula Christian, Fachhochschule Pforzheim, Germany

Experience and Innovation – The Art of Creating Brilliant Images

See what you've been missing

The Leica name has always represented the highest standards in optical performance. The development of our HC optics set completely new standards. The innovative HC objectives exploit all the possibilities offered by modern optics for faithful reproduction and contrast, particularly in demanding material science microscopy.

The optical talent

Large working distances and simultaneously high resolution are what you expect of objectives on a professional class materials microscope. The response from Leica is HC optics with objectives that offer you the highest possible numerical aperture combined with the maximum possible space on the specimen stage. You will experience high-contrast, pin-sharp, detailed structures like you've never seen before in all contrast techniques; brightfield, darkfield and interference contrast.

Why not do it fast – the automatic objective change

You know it well, the awkward procedure of switching from a low-magnification overview objective to high magnification and back again. This often time-consuming, vibration producing and impractical process is now a thing of the past with the Leica DMI 5000 M. Just touch the button and the objective is changed automatically with perfect parfocality.



The motorized 5x objective turret

A touch of the button is enough to change the objective. The display shows the current objective magnification and the overall magnification immediately.



The Industrial Solution

A microscope must meet stringent requirements if it is to be used for industrial applications. The integrated solution shown below comprises a Leica DMI 5000 M for reflected light and transmitted light examinations with manual stage, motorized objective turret, motorized focus and a DFC280 camera.

Leica DMI 5000 M:

- The Parfocality Manager guarantees a sharp image at all times – even after changing the magnification.
- Just touch the button for a quick switch between reflected light and transmitted light.
- The objectives are switched fully automatically.

Leica DFC280

- The camera features a FireWire port for fast image transfers.



The Perfect Configuration for Every Task

Security for the future –

this microscope can grow with your requirements

Speed and reproducibility is paramount for examination of a large number of similar specimens under identical conditions. The ideal tool for such tasks is the Leica DMI 5000 M – material microscopy has never been faster or easier. Automatic objective change with intelligent aperture and light intensity adjustment, motorized focus and automatic contrast manager including fully automatic DIC functions will make short work of even your most demanding imaging requirements. You concentrate on your results while the ultimate microscope controller manages the DMI 5000 M. You can of course choose to customize your Leica DMI 5000 M to your exact motorization requirements.

Flexibility is the key

You can choose the degree of automation your specimens and examinations require. The modular design of the DMI 5000 M gives you a free hand – whether you want a manual focus drive or a manual stage. The configuration depends on the task and your preferences.

Versatility is the Leica standard

View machined metal surfaces with reflected light or powder examinations with transmitted light – it's your decision. With the Leica DMI 5000 M you are working with our new reflected-light contrast manager for brightfield, dark field, DIC and qualitative polarization. Transmitted light is just a touch of a button away; here brightfield, dark field, DIC, POL and phase contrast imaging is at your fingertips insuring consistency and designed for the simplest possible operation.

Flexibility



System status at a glance

All settings of the microscope can be read on the status display at a glance. The reflectors for the various contrast processes or magnification changers can be selected directly at the front panel.



Add components with ease

Reflectors for contrast processes or fluorescence filters can be added through the access port. It opens at the touch of a button; the reflector can be replaced in seconds.



Zinc, POL, 1:50

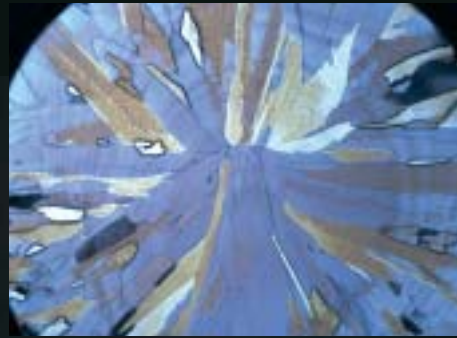

Copper-zinc rod, POL, 1:16



Zinc, POL, 1:50

Photos: Ursula Christian,
Fachhochschule Pforzheim, Germany



Intelligent Imaging – At the Touch of a Button.

Let there be light

You know you must adjust brightness and apertures for every change of objective to insure the best image. Consider how many times a day you do that! As of now, it's history! The illumination manager of the Leica DMI 5000 M will handle it for you reliably. When changing magnification or contrast technique, it automatically sets the brightness, aperture and field diaphragm to their optimal values. When you switch to a higher magnification, the Leica DMI 5000 M immediately adapts the values that you set previously to the lighting. What if you have special requirements regarding the settings? Then you simply change them and they are immediately stored by the microscope and implemented at the next examination.

Bright white

The key: the integrated CCIC (Constant Color Intensity Control) keeps the color temperature at a constant 3200 K. Even at low lamp voltages your images of such items as steel or ceramic specimens will no longer have a red cast – color rendition no longer depends on the lamp intensity.



Constant Color Intensity Control (CCIC)

The reflected-light axis has an automatic CCIC module. It consists of a glass disk with a step-less blue filter. Thanks to its voltage-dependent rotation, this module ensures a constant incident-light color temperature of 3200 K.



The Illumination Manager

The Leica illumination manager, located on the left side of the DMI 5000 M, enables personalized settings of aperture and light intensity values. The device stores the light intensity and field and aperture stop values that you specify for every objective. You can also switch between reflected and transmitted light at the touch of a button. The manager stores every change and indicates it in the display.

A Disk Like No Other



Aluminum-silicon, Brightfield

1:20

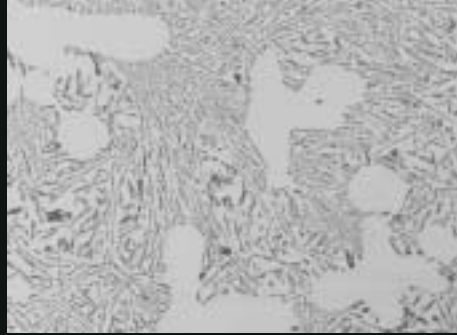

Aluminum-silicon, Brightfield

1:50



Aluminum-silicon, Brightfield

1:100

Photos: Ursula Christian,
Fachhochschule Pforzheim, Germany



This universal genius is concealed in the reflected-light axis. The CCIC module uses voltage-dependent rotation to generate a constant color temperature of 3200 K in reflected light – this means that the color sensation is independent of the image brightness and the magnification.

Intelligent Imaging – At the Touch of a Button.

Contrast – as if by magic

Manual operation of reflectors is now a relic of the past. With the Leica DMI 5000 M it is enough to touch the “DF” button and dark field contrast is adjusted automatically. The microscope knows the appropriate reflector required for dark field contrast and inserts it into the optical path.

Differential interference contrast is even more exciting: just touch the button and the analyzer, polarizer and appropriate prism for the objective are positioned into the optical path. It is really this easy to change the contrast process: whether you want a reflected or transmitted light process – all it takes is a touch of a button.

MYcroscopy

The Leica DMI 5000 M offers you a total of seven freely programmable buttons to which you can map your most important functions. Use them to create your own microscope – put the functions you need wherever you want them.

Once in focus – always in focus

The advantages of the Leica DMI 5000 M include the option of selecting manual z-focus or motorized z-focus with parfocal function. An objective set is always calculated to ensure that the focus levels of its objectives are in the same z-level. However, there may be minor variations as a result of manufacturing tolerances. As a result, it is necessary to correct the focus after changing objectives. The parfocal function of the Leica DMI 5000 M motorized focus drive compensates for different focus levels. In addition, the focal plane and a lower plane can be stored and selected automatically.



Free programming

Four of the freely programmable buttons are located on the left side of the microscope. Three additional keys on the right side are also available. If you use the SmartMove remote control an additional four freely programmable buttons can be utilized. Each of the buttons makes it possible to configure a microscope to match your requirements perfectly.



The Focus Manager

The Focus Manager stores, manages and travels to two focal planes and is located on the right-hand side of the microscope. In addition to storing the focal plane, an additional lower level can be stored to ensure reliable objective changing, even with complex stage setups.

Examination for Steel Purity

A microscope system used for assessing the purity of steel must meet stringent requirements. The system illustrated here is a fully integrated solution. The Leica DFC280 digital camera, the DMI 5000 M microscope and the "Steel-Expert" user software

Leica DMI 5000 M:

- The motorized focus combined with the parfocal manager guarantee a sharp image at all times – even after changing the magnification.
- The "Inclusion Counter" integrated in the stand can be activated by the touch of a button.
- Fully automatic switching between overview and working objective.

Leica DFC280:

- The camera features a FireWire port for fast image transfers.

Leica Steel-Expert Software:

- The software solution is fitted with driver modules for camera and microscope, permitting the remote control of the entire system.



Intelligent Imaging – At the Touch of a Button.

Steel purity examination made easy

The Leica DMI 5000 M with the “Inclusion Counter” will make your steel purity examinations fast and easy. Just touch a button and a quadratic field of 0.71 x 0.71 mm is illuminated with an objective with 10x magnification. This allows the purity to be determined in full compatibility with the standard.

My microscope thinks too

The combination of the Leica DMI 5000 M and the “Steel Expert” software package is ideal for steel purity examinations. The software does routine tasks such as assessment of sulfides, silicates or TiN inclusions quickly, easily and with maximum precision. You can use the “Steel Expert” software package to localize, identify and evaluate non-metallic inclusions in steel automatically. “Steel Expert” also solves the problem of the large number of different standards and associated incorrect interpretations. You inform the program of the standard to be used for the evaluation and the Leica DMI 5000 M Steel Expert does the rest.

Clearly visible wherever you look

The graphical display has been structured so that you can take it in with a glance. Information on the objective and total magnification, the contrast process or current lighting setting are displayed as well as the current stage and focus position. The Leica DMI 5000 M also offers the option of taking easy and convenient height measurements.

Everything at a glance

Touching a button on the front panel can access the most important functions of process switching, interim magnification or the current camera output. Feedback is provided immediately on the display.

Integration



Status display

All current settings of the microscope at a glance: the current contrast process, selected magnification, specified lighting parameters, selected camera output and information on the focus level can all be read from the display.



Clearly designed controls

The front control panel shows the most important functions. Every reflector cube can be directly controlled. Touch a button to open or close the shutter, switch the camera output or adjust the interim magnification of the specimen. Feedback is provided immediately on the display.

Image Documentation – Always With the Optimum Setting

Focus at the touch of a button

Brand new: the autofocus software module for digital cameras. When using a Leica DFC280, DFC320 or DFC480, you can now take advantage of an autofocus program that automatically finds and holds the focal plane.

Digital cameras for any application

Leica digital cameras feature standard FireWire ports for fast image transfers to PCs and Macintosh computers. The range covers everything from color cameras for a variety of applications to monochrome cameras with cooling systems for high-resolution fluorescence images. All digital cameras have variable resolution with live-image mode; image resolutions extend from 1.3 to 12 mega-pixels at a color depth of up to 14 bits per color channel.



A Team is More Powerful Than the Sum of its Players

Four eyes see more than two

The Leica DMI 5000 M has three camera outputs, the right one for every camera. Two motorized outputs (left and right) enable you to switch from 0/100% or 50/50% or 80/20% as required – all it takes is a touch of a button. A further mechanical port on the tube was developed for users that do not have room at the sides due to accessories. A special feature of the camera port program: you can choose freely which ports to use and how much light they will receive. You can select from a range of 13 different components – optical prisms of varying transparency – to generate a variety of different camera output types. There's a camera port option to match your ideal application solution.

Repetition required

An experiment is often repeated weeks or even months later with new specimens for comparison. Until now, that was difficult to realize. Taking exactly comparable images was virtually impossible. Not so with Leica's new Store & Recall module! This software module stores the complete settings of the microscope together with the image. If a new specimen must be imaged under the same conditions, you only need to touch a button – and the microscope will restore the original conditions. Up to and including light settings and fine adjustment of the DIC prism!

Our microscope – a perfect fit for all users

Different users frequently use the same microscope. Each user often has unique personal requirements. With our MUP (multi-user package) software, you can easily create and store custom microscope configurations for each user and restore them by entering a personal password.



Leica DFC320 digital camera

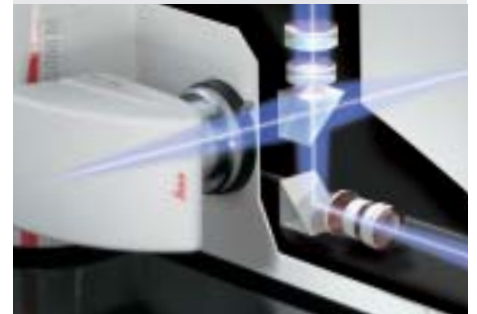

Motorized camera outputs

A motorized disk with four positions that can be equipped to suit your individual requirement controls the two lateral ports. Beam splitters can be installed, which direct 100%, 80% or 50% of the light as desired to the left or right output port. All you need to do is touch a button to set it to the desired position.



Mechanical camera output

The top camera port on the tube is mechanical. Switch settings are 0/100% or 100/0%.

Stand	Power supply Display Interfaces	Leica DMI 5000 M <ul style="list-style-type: none"> • In CTR4000, CTR6000 or CTR6500 electronic box • Information display 77 x 49 cm (W/H) • 2 x RS232 • 2 x USB
Focus	General	<ul style="list-style-type: none"> • Motorized or manual • 5 electronic speeds with motorized types • Switching between coarse and fine mode
Objective turret		<ul style="list-style-type: none"> • 5x M32 • Motorized, absolute coding
Controls	Stand SmartMove (remote control)	<ul style="list-style-type: none"> • 7 freely programmable buttons • Buttons with fixed functions for <ul style="list-style-type: none"> – illumination manager, focus functions, camera ports, subsequent magnification, fluorescence functions • Control element for focus (z) and stage movement (x, y) • 4 freely programmable buttons
Stages	Mechanical stages Motorized stages	<ul style="list-style-type: none"> • Fixed stages <ul style="list-style-type: none"> – ceramic-coated – various attachments available • 3 plate cross stages (manual or motorized) • Spindle stage (scanning stage)
Automation	Focus (optional) Illumination Manager, transmitted light Contrast manager	<ul style="list-style-type: none"> • Including parfocality function • Positioning memory slots for fast travel to 2 z-positions • Adjustment of brightness, aperture and field diaphragms to the objective and contrast method currently in use • Adaptation of optical elements such as prisms or light rings to the objective and contrast method currently in use • Adjustment of field diaphragm to the eyepieces or camera chips (round or rectangular diaphragms)
Reflected-light axis	CCIC Contrast method Reflector disk	<ul style="list-style-type: none"> • Constant Color Intensity Control – maintains color temperature of 3200 K • BF, DF, POL, DIC, FL • Motorized, for up to 4 reflectors (2 x fixed, 2 x adjustable) • 12 V/100 W halogen lamp • Motorized field diaphragm • Filter magazine for 2 filters (filter slider) • Integrated closure (shutter)
Condensers	General S1–28	<ul style="list-style-type: none"> • Motorized condenser disk for optical elements with <ul style="list-style-type: none"> – 4 large openings for prisms, DF stop, BF, PH rings – 3 small openings for BF, PH rings • Integrated motorized aperture diaphragm • Suitable for magnifications from 1.25x to 100x • Motorized flip-top condenser head (mechanical optional)
Transmitted light axis	Illumination arm	<ul style="list-style-type: none"> • 12 V/100 W halogen lamp • Motorized field diaphragm • Integrated closure (shutter)

Specifications

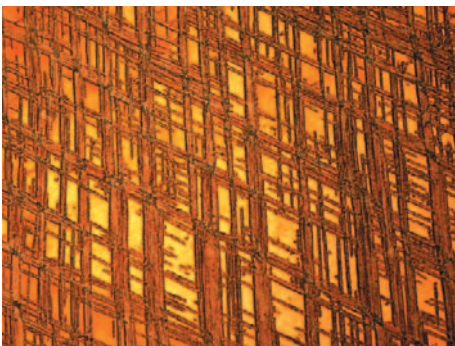
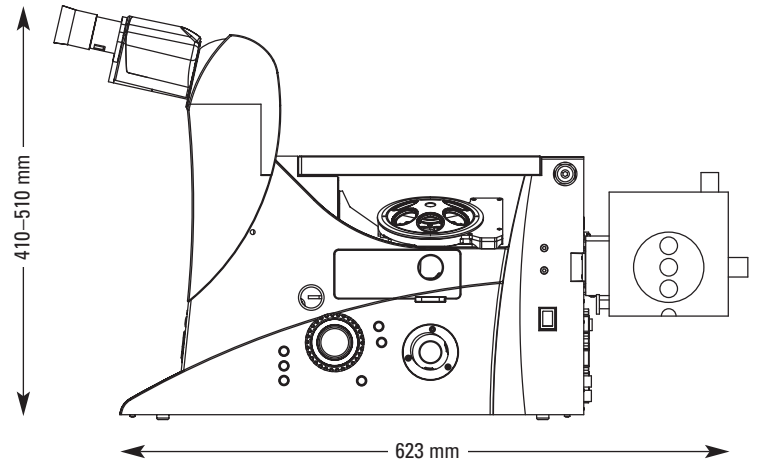
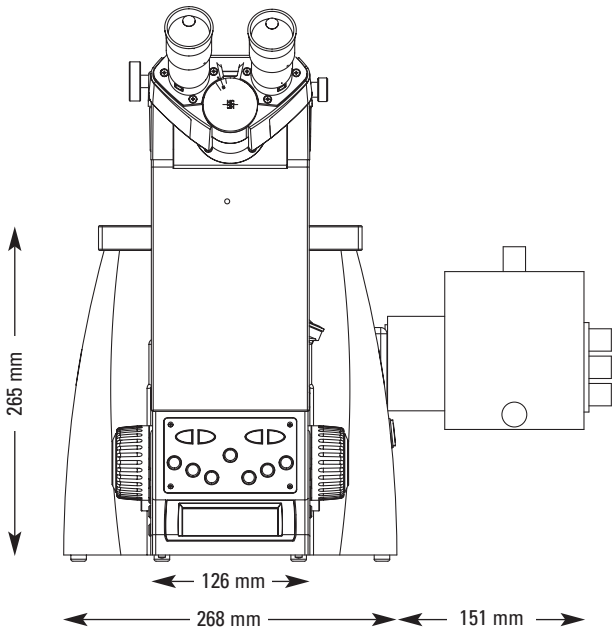

Copper-zinc deformation lines, 1:1500



Tin with deformation twins, 1:100

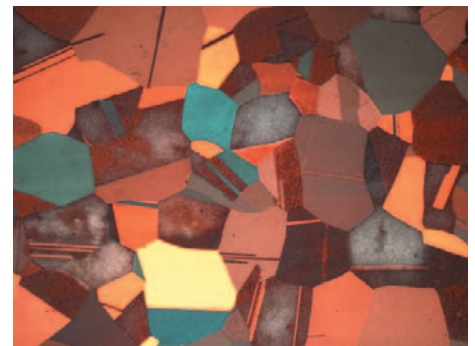

Tin bronze with recrystallization twins, 1:200

System overview

Leica DMI5000 M

TV systems

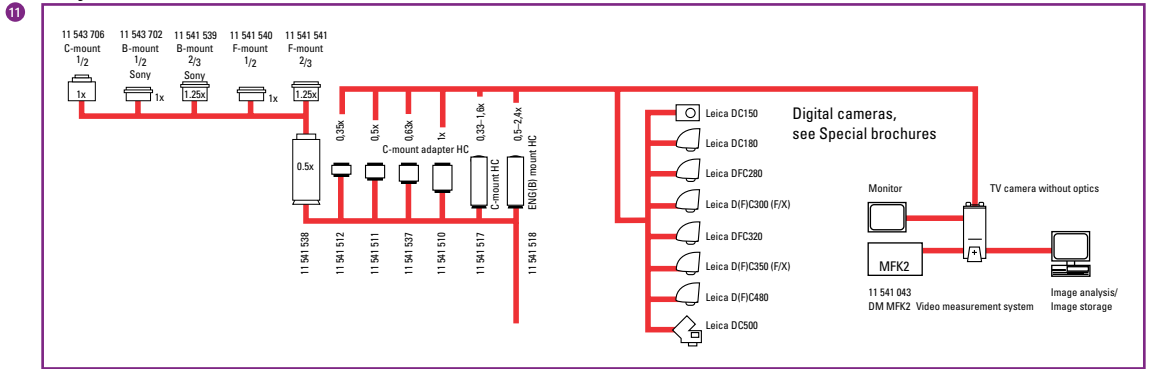

Incident light/transmitted light lamp housings

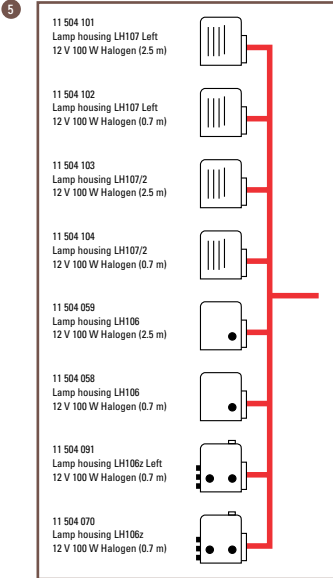

Bino-ergo tube

11 888 277 without Bertrand lens

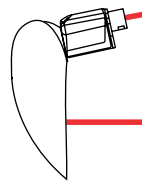

Trino-ergo tube

11 888 275 without Bertrand lens with 50/50 Photo output
11 888 324 with 100% Photo photo output

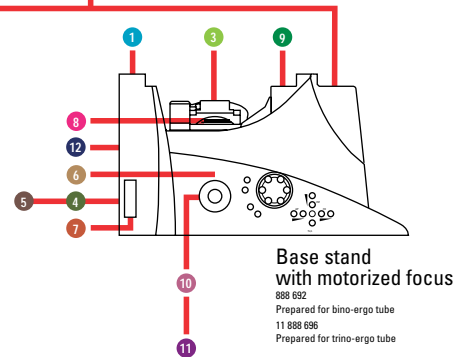
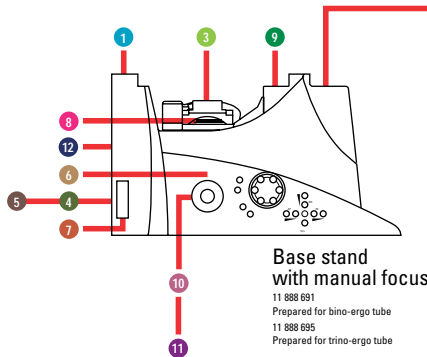
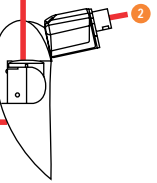

Lamp housing mount

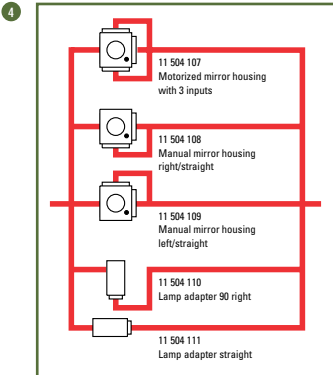

Fluorescence lamp housings

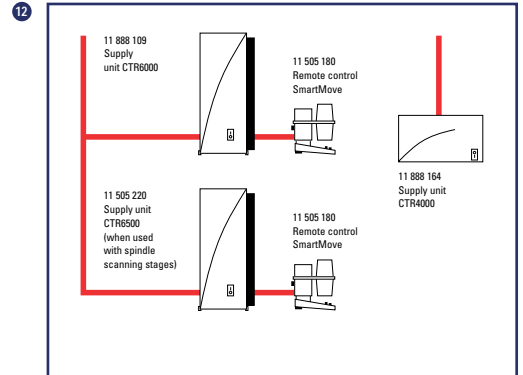
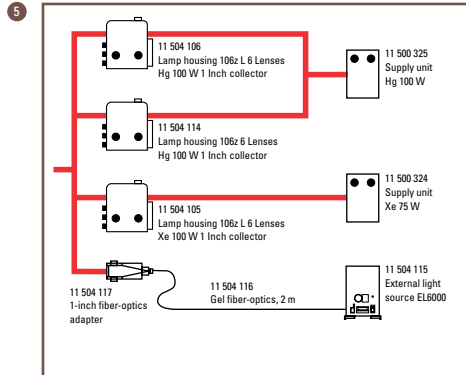

Transmitted light axis

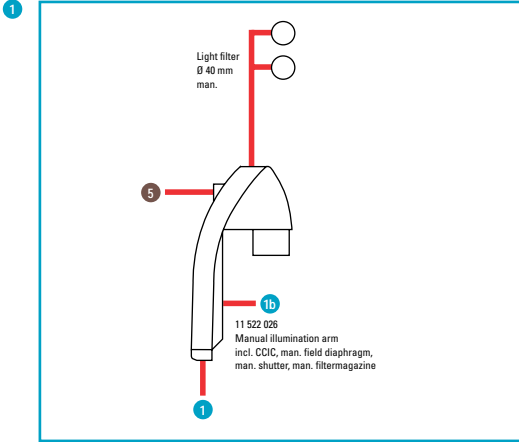

Condensers

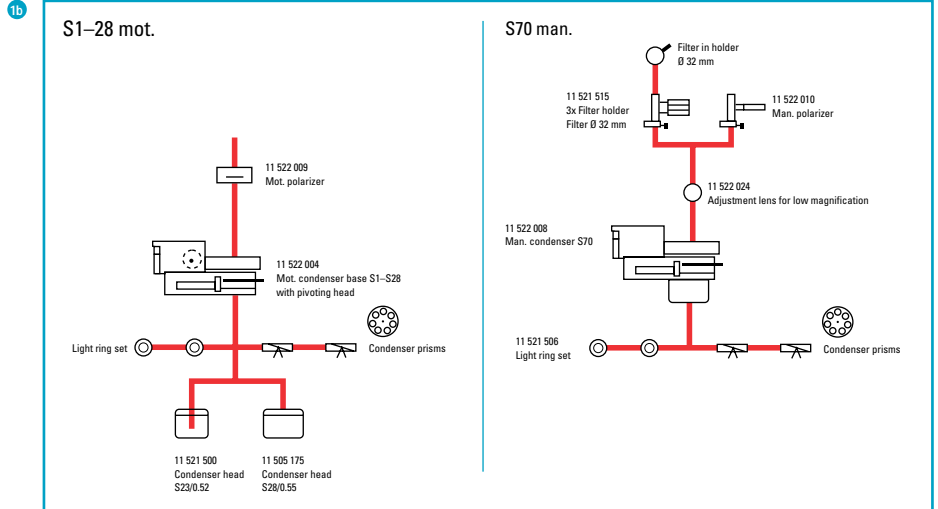

Eyepieces

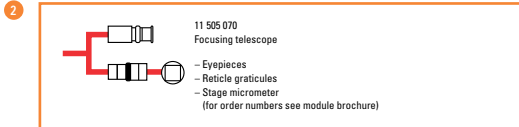

Objectives

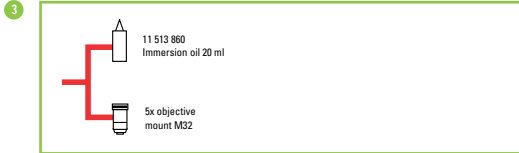

Incident light axis and magnification changer

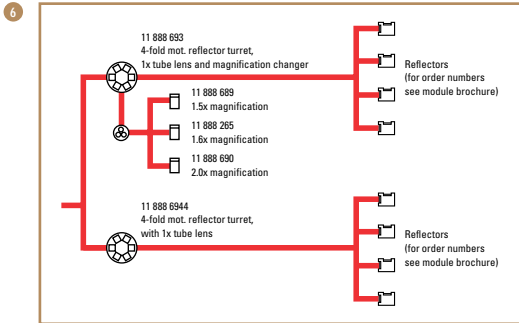

Incident light filter slide



DIC systems

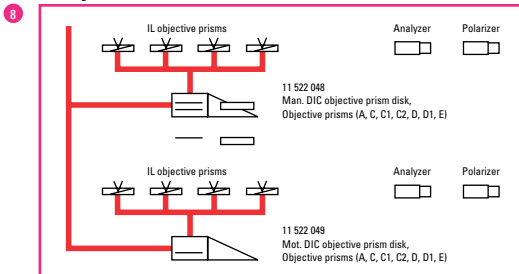

Stages

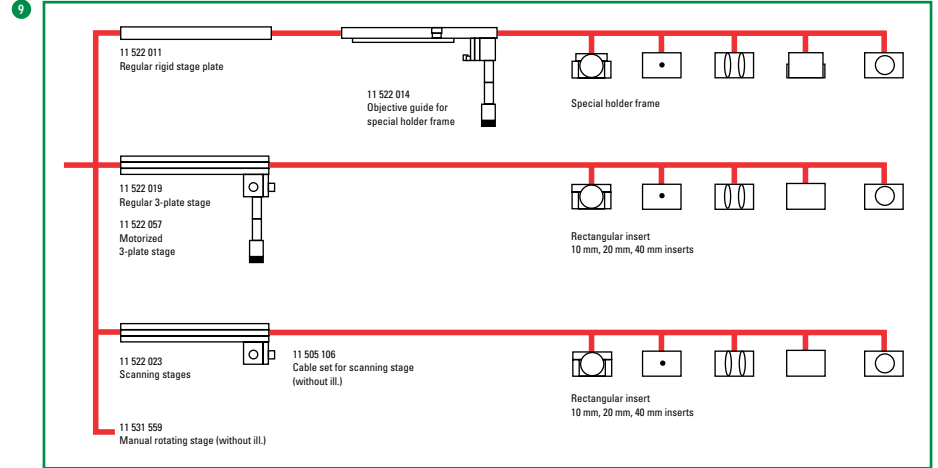

Side ports

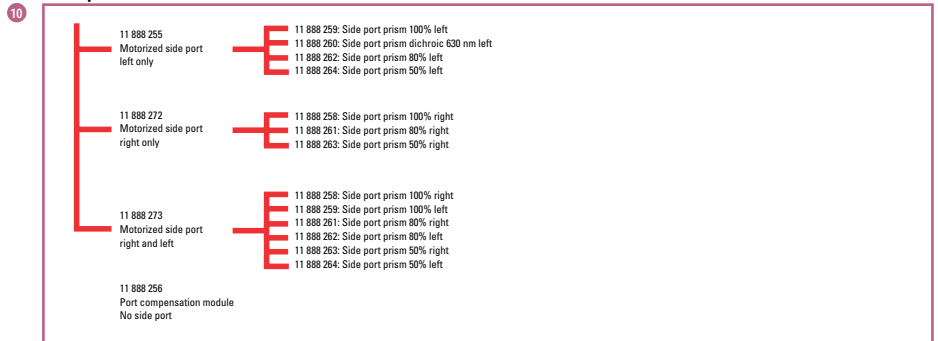

LAS Software Upgrades



Leica Microsystems – the brand for outstanding products

Leica Microsystems' mission is to be the world's first-choice provider of innovative solutions to our customers' needs for vision, measurement, lithography and analysis of microstructures.

Leica, the leading brand for microscopes and scientific instruments, developed from five brand names, all with a long tradition: Wild, Leitz, Reichert, Jung and Cambridge Instruments. Yet Leica symbolizes innovation as well as tradition.

Leica Microsystems – an international company with a strong network of customer services

Australia:	Gladesville	Tel. +61 2 9879 9700	Fax +61 2 9817 8358
Austria:	Vienna	Tel. +43 1 486 80 50 0	Fax +43 1 486 80 50 30
Canada:	Richmond Hill/Ontario	Tel. +1 905 762 2000	Fax +1 905 762 8937
Denmark:	Herlev	Tel. +45 4454 0101	Fax +45 4454 0111
France:	Rueil-Malmaison	Tel. +33 1 473 285 85	Fax +33 1 473 285 86
Germany:	Bensheim	Tel. +49 6251 136 0	Fax +49 6251 136 155
Italy:	Milan	Tel. +39 0257 486.1	Fax +39 0257 40 3273
Japan:	Tokyo	Tel. + 81 3 5421 2800	Fax +81 3 5421 2896
Korea:	Seoul	Tel. +82 2 514 65 43	Fax +82 2 514 65 48
Netherlands:	Rijswijk	Tel. +31 70 4132 100	Fax +31 70 4132 109
People's Rep. of China:	Hong Kong	Tel. +852 2564 6699	Fax +852 2564 4163
Portugal:	Lisbon	Tel. +351 21 388 9112	Fax +351 21 385 4668
Singapore		Tel. +65 6779 7823	Fax +65 6773 0628
Spain:	Barcelona	Tel. +34 93 494 95 30	Fax +34 93 494 95 32
Sweden:	Sollentuna	Tel. +46 8 625 45 45	Fax +46 8 625 45 10
Switzerland:	Glattbrugg	Tel. +41 1 809 34 34	Fax +41 1 809 34 44
United Kingdom:	Milton Keynes	Tel. +44 1908 246 246	Fax +44 1908 609 992
USA:	Bannockburn/Illinois	Tel. +1 847 405 0123	Fax +1 847 405 0164

and representatives of Leica Microsystems
in more than 100 countries.

The companies of the Leica Microsystems Group operate internationally in four business segments, where we rank with the market leaders.

● Microscopy Systems

Our expertise in microscopy is the basis for all our solutions for visualization, measurement and analysis of microstructures in life sciences and industry. With confocal laser technology and image analysis systems, we provide three-dimensional viewing facilities and offer new solutions for cytogenetics, pathology and materials sciences.

● Specimen Preparation

We provide comprehensive systems and services for clinical histo- and cytopathology applications, biomedical research and industrial quality assurance. Our product range includes instruments, systems and consumables for tissue infiltration and embedding, microtomes and cryostats as well as automated stainers and coverslippers.

● Medical Equipment

Innovative technologies in our surgical microscopes offer new therapeutic approaches in microsurgery.

● Semiconductor Equipment

Our automated, leading-edge measurement and inspection systems and our E-beam lithography systems make us the first choice supplier for semiconductor manufacturers all over the world.

 www.simply-microscopy.com

LEICA
MICROSYSTEMS